

Assembly Manual

ESR & Low Ohms Meter

K-7204

Reproduced in part by arrangement with Electronics Australia, from their February 1996 edition.

Please read Disclaimer carefully as we can only guarantee parts not the labour content you provide.



If you repair switch-mode power supplies, TV receivers, computer monitors, vintage radios, or similar equipment, and/or if you need to measure very low values of resistance, this project can save you lots of time and aggravation - as it has for me. It measures an aspect of electrolytic capacitor performance which is very important, but normally very difficult to check: the equivalent series resistance, or 'ESR'.

Some wise person once said, "The reliability of any piece of electronic equipment is inversely proportional to the number of electrolytic capacitors in it", and I doubt that many service technicians would disagree!

Especially now that switch-mode power supplies (SMPSs) have been commonly used in domestic VCRs and TVs, etc for a decade or so, one of the most likely components to fail is the humble electrolytic. The symptoms can be as diverse as a VCR's playback picture swimming in tiny dots, up to SMPSs mysteriously self-destructing.

As a service technician myself (though I'd prefer to be a full-time designer!), I was just about tearing my hair out because of the difficulty in determining which electros were faulty and which ones were still OK, in SMPSs and other equipment. I wanted to be able to check electros in circuit, with the power safely disconnected.

Why not use a readily-available capacitance meter? Because when electros go faulty, they normally don't lose their capacitance significantly (as many technicians assume they do). Rather their equivalent series resistance (ESR) 'goes through the roof'. Capacitance meters don't tell you this;

about the best they can do is give a low reading if the electro is nearly open circuit.

About ESR...

So what exactly is an electrolytic's equivalent series resistance?

Electrolytics depend on a water-based electrolyte, soaked into a strip of porous material between the aluminium foil plates, to complete the 'outer' electrical connection to the aluminium oxide dielectric coating on the anode foil.

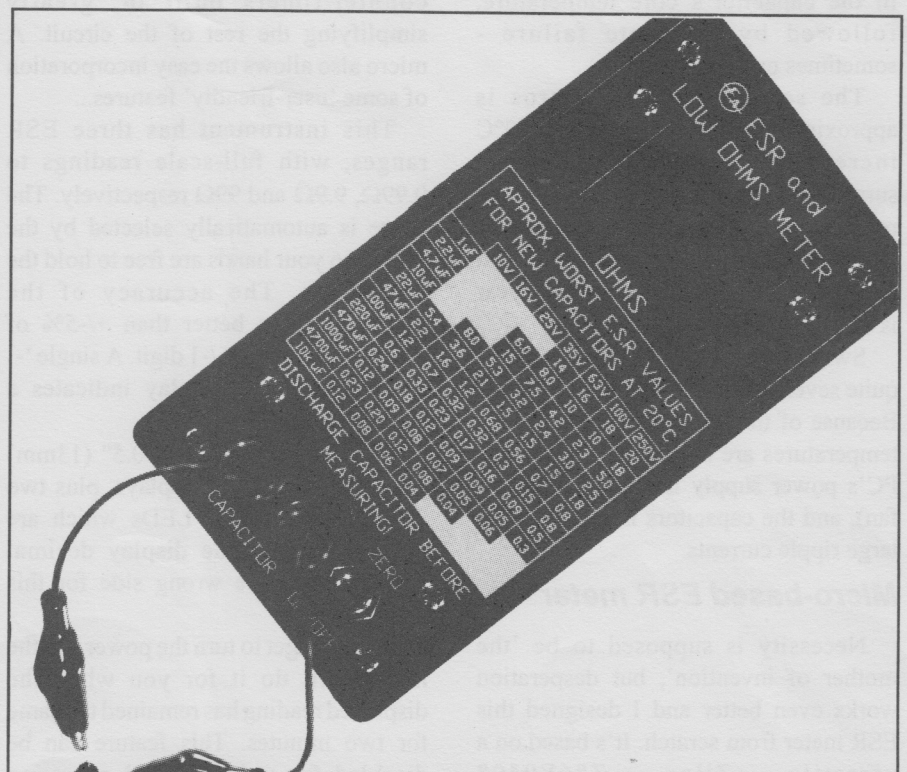

The electrolyte has electrical resistance which, along with the (negligible) resistance of the connecting leads and aluminium foil plates, forms the capacitor's equivalent series resistance.

Normally the ESR has a very low value, which stays that way for many years unless the rubber seal is defective. Then the electrolyte's water component gradually dries out and the ESR creeps up with time. The electro gradually acts more and more like a capacitor with its own internal series resistor...

Heat makes it worse

If an electro is subjected to high temperatures, especially from heat generated internally as a result of large ripple currents, the electrolyte will start to decompose and the dielectric may deteriorate - and the ESR will increase far more rapidly.

To make things worse, as the ESR increases, so does the internal heating caused by ripple current. This can lead to an upward spiral in the capacitor's core temperature, followed by complete failure - sometimes even explosive!

The service life of electros is approximately halved for every 10°C increase in temperature and, surprisingly, many are designed for a reliable operating life of only a few thousand hours at their maximum rated temperature and ripple current. (A year is only 8766 hours!)

Switch-mode power supplies place quite severe stresses on filter capacitors. Because of their compact construction, temperatures are high (that's why your PC's power supply is equipped with a fan), and the capacitors have to endure large ripple currents.

Micro-based ESR meter

Necessity is supposed to be 'the mother of invention', but desperation works even better and I designed this ESR meter from scratch. It's based on a versatile Zilog Z86E0408

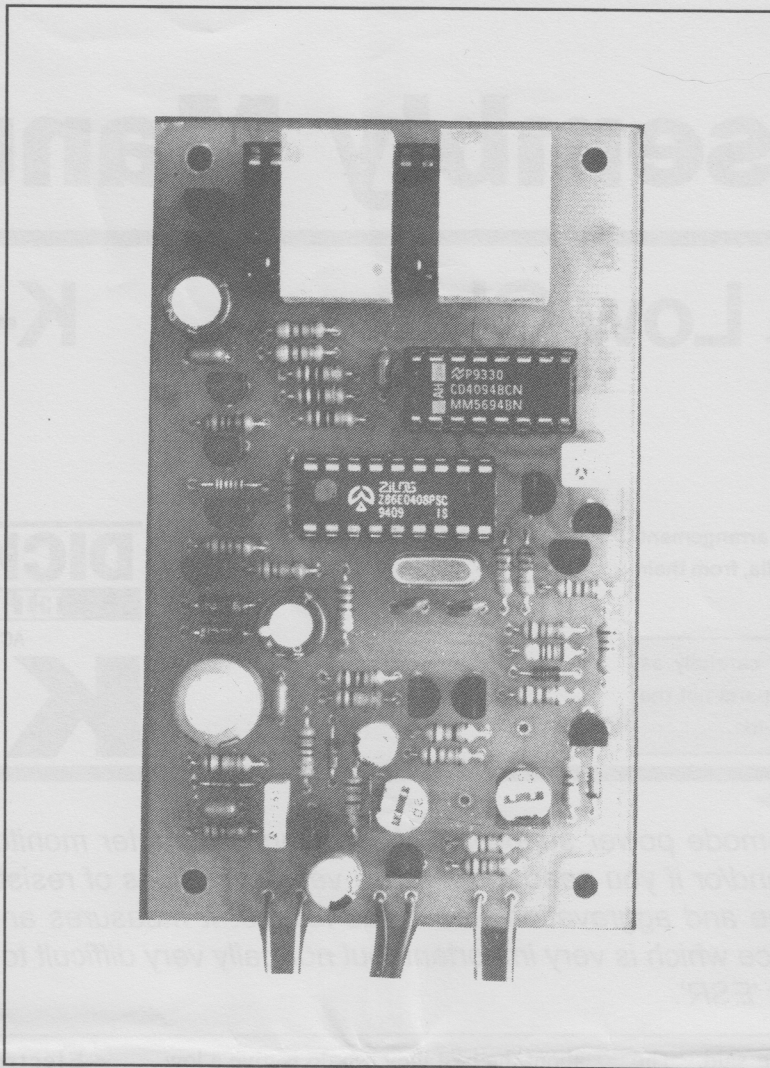

A close up view of the ESR meter PCB, showing the position and orientation of all the parts - except the test leads, push button and battery. Note that the LED displays and decimal point LEDs are mounted via a 28-pin IC socket.

microcontroller - which already has two voltage comparators and two flexible counter/timers built in, greatly simplifying the rest of the circuit. A micro also allows the easy incorporation of some 'user-friendly' features...

This instrument has three ESR ranges, with full-scale readings to 0.99Ω, 9.9Ω and 99Ω respectively. The range is automatically selected by the micro, so your hands are free to hold the test leads. The accuracy of the prototypes was better than +/-5% of displayed reading, +/-1 digit. A single '-' on the left-hand display indicates a reading above 99Ω.

The readout is on two 0.5" (13mm) seven-segment LED displays, plus two 3mm decimal point LEDs which are needed because the display decimal points are on the wrong side for this application.

If you forget to turn the power off, the micro will do it for you when the displayed reading has remained the same for two minutes. This feature can be disabled for uninterrupted operation

from a 9V optional plugpack.

When the battery voltage is nearly too low for the circuit's 5V regulator to function correctly, the Z86 reduces the power to the LED displays and flashes a 'b' on the right-hand one in the 'off-scale' condition, to warn you to look for a new battery

Meter operation

There's a single pushbutton, which has three functions: one press turns the power on, and another press will switch it off again if the measured resistance is 1Ω or more.

A push of the button with the leads shorted together will cause their resistance value to be subtracted from all subsequent readings, as long it's less than 1Ω.

Before making a measurement on an electrolytic, first discharge it. I find a 100Ω 5W does this well. Then connect the test leads - either way around. If your

capacitor is still in circuit (with the power OFF!), you're likely to get quite an accurate reading, because it should be the component with by far the lowest high-frequency impedance.

The circuit's test signal has a peak open-circuit voltage of 600mV (maximum 100mV peak at full-scale reading), so it won't make diodes or transistors conduct and cause measurement errors. Compare the reading you get with the front-panel table, to get an idea of whether the electro's ESR is about normal or significantly above it.

The table's approximate 'worst ESR' figures were taken from the Nippon Chemi-Con Aluminum Electrolytic Capacitors Catalog Number 4, as 100kHz impedance figures for their 'SXE', 'SXG' and 'LXA' capacitor series. They agree pretty closely with my own measurements of many new electros of assorted brands, styles, sizes and ages.

From my actual faultfinding experience with the prototypes, an

electro's ESR needs to be many times the table value before it's likely to cause trouble.

Low ohms uses

The instrument is very handy for measuring low values of resistance, too. But note that because it makes an AC measurement, it can't give a sensible indication of the DC resistance of inductive components, such as transformer windings or chokes.

I've used it to 'roll my own' low value resistors, by measuring off the required number of (milli) ohms of DSE catalog number W-3200 resistance wire, which I then formed into a spiral by wrapping it around a drill shank.

It can also locate short circuits on PC boards, by measuring actual track resistances. If the reading increases as you probe further along the track, you know you're going in the wrong direction!

You could also use it to confirm solid continuity of mains lead earth conductors, etc, etc...

What NOT to do

There are a few minor points to keep in mind, when using the meter. First, it can't identify leaky or short-circuited capacitors - that's what the resistance ranges of normal multimeters are for! Also, avoid using self-retracting 'curly' test leads, because their inductance can cause small measurement errors.

Lastly, don't use the meter right next to an operating TV set or computer monitor - the high amplitude pulses radiated by the horizontal output stage can be picked up by the test leads and cause unstable readings.

The circuit

Now let's have a brief look at how it all works, by reference to the schematic.

A push of the button switches on Q1, supplying +9V to IC1, the 5V regulator. Once the Z86E0408 microcontroller ('Z86' for short) starts up, it forward biases Q2. This holds Q1 on, maintaining the 5V supply after you release the button.

The displays are driven by IC3, an eight bit serial-in parallel-out shift register. IC3's outputs are connected to both seven segment displays and the decimal point LEDs in parallel. Cathode driver transistors Q12 and Q13 are configured so that only one display and its decimal point LED can illuminate at a time, under control of the Z86's pin 18.

Every 5ms the Z86 serially updates

the segment and decimal point data in IC3, and swaps displays; at this speed it appears both displays are continuously illuminated.

The Z86 starts a measurement by grounding its pin 4, switching on current mirror transistors Q9 and Q10 and causing C10 to begin charging at a constant rate. Under control of its firmware, the Z86 drives Q3, 4 or 5 to apply short current pulses of 0.5, 5 or 50mA, via C5/6, to the capacitor being tested. The resulting voltage pulses, proportional to the electro's ESR, are amplified by Q7 and Q8 (no relation to the one in the Persian Gulf!), and compared with C10's voltage. Q6 functions as a ground reference switch.

A simple time measurement allows the Z86 to determine the amplitude of the voltage pulses and so the capacitor's ESR. At the end of each measurement, Q11 is used to discharge C10.

Then the Z86 subtracts the test lead resistance (if it's been zeroed), and displays the value.

Now for the 'frills'...

Battery voltage check: The Z86 regularly allows C10 to charge to 2V. If the battery voltage sample on VR1's wiper (fed in via pin 9) drops below this 2V level, the 'battery low' warning condition is triggered.

Protection: Sooner or later this meter will find itself connected to an unexpectedly charged capacitor (or worse), so some protection has been built in. D3, D4, D5 and D6 are strategically placed to prevent destructive voltages from finding their way back to the microcontroller; D4 also limits the test voltage to 0.6V peak.

The rest: When the Z86 detects the button is pushed while measuring a resistance of one ohm or more, it switches off Q2 and displays question marks until your finger leaves the button. Then Q1 switches off the battery supply.

Crystal XTAL1, C11 and C12 complete the Z86's clock oscillator, which provides the timing for all the meter's operations.

Construction

As the photos show, every component except the pushbutton is mounted on a 57 x 95mm PC board, coded ZA1245 (96ESR1).

Before fitting any components to the PCB, first illuminate its component side with a bright light, and examine the copper side carefully for fine track breaks and especially whiskers or bridges - particularly where tracks pass

between IC socket pads.

If you're planning to run the ESR & Low Ohms Meter from a optional (not supplied) 9V plugpack, leave R25 (47k) off the PCB. This will disable the two minute automatic switchoff function, and also the low battery warning...

When you're soldering the components to the PCB, using the overlay diagram as a guide, bear in mind that the PCB is tightly packed and the solder pads are small. The last thing this circuit needs is solder bridges and bad joints.

Begin installing the components, starting with the lowest-height ones (resistors and diodes), and working your way up to the tall ones. Note that the displays and LEDs are mounted on a 28-pin IC socket, not soldered directly to the PCB!

It's a good idea to double-check, especially at the beginning, that you're putting each component's leads into its correct holes. They're rather closely-spaced...

Take care with the orientation of the polarised components, and make sure the different transistor types and IC1 all go in their correct places. Don't install the socketed parts just yet, though.

When everything's on the PCB, once again illuminate it from the top, and check for and correct any solder bridges or other problems.

Making a display

Next study the display area in the photo of the PCB. Then, keeping the cathode (short) leads of the decimal point LEDs to the right, cut the leads down to about 9mm long. Use long-nose pliers to 'dog-leg' the leads about 3mm from the ends, so the LEDs will be about level with the bottom of the seven-segment displays when installed.

Push the LEDs into their places in the 28-pin socket, followed by the seven-segment displays themselves, ensuring their decimal points are at the bottom, and they are properly seated.

First test

Solder the battery snap leads to their pads, making certain their polarity is correct, and solder long component lead offcuts to the 'capacitor' and 'button' pads. Temporarily solder the pushbutton to the ends of its leads, then turn VR1 fully clockwise, and set VR2 to mid-range.

Using alligator clip leads or similar, connect a variable DC power supply set for 9V (and preferably with about 50mA

current limiting) to the battery snap terminals. Make sure the positive lead goes to the clip, and the negative to the stud. You can use another battery snap to make the connection, but remember that its black lead will be the positive one!

Hold the button down and check that pin 5 of IC2's socket and pin 16 of IC3's socket have +5V on them, relative to the power supply negative. If they have, discharge any static electricity by touching something earthed, then install IC2 and IC3 in their sockets and double-check their orientation.

Push the button for a second or so, and you should see 'EA' flash on the displays for a moment, followed by a single '-' on the left-hand one. If not, carefully recheck the PCB and its soldering and component placement, until you find the problem.

Now short the 'capacitor' leads, and the display should indicate a resistance of around .03 ohms. Push the button again and this should change to '.00', possibly with the least significant digit hesitating between 0 and 1.

Calibration

Connect a resistor of known accuracy of around 68 to 82 ohms to the 'capacitor' leads, and adjust VR2 for a correct reading. Now try a resistor in the range of 1 to 9 ohms, and check that the meter reads close to the correct value.

Battery Warning: Skip this bit if you disabled the automatic switchoff

Parts list

Resistors

(All 0.25W 5% unless noted)

R1,19,20,21,23,24	10k
R2,27,28	4.7k
R3,26	15k
R4,25	47k
R5,7,9,15	2.2k
R6	10k 1% M/F
R8	1k 1% M/F
R10	100Ω 1% M/F
R11	220Ω
R12	1k
R13	100k
R14	220k
R16	180Ω
R17	6.8k
R18	680Ω
R22	470k 1% M/F
R29	2.7k
VR1	10k hor. trimpot
VR2	200Ω hor. trimpot

4-band 5%

brn-blk-org-gld
yel-vio-red-gld
brn-grn-org-gld
yel-vio-org-gld
red-red-red-gld
brn-blk-org-brn
brn-blk-red-brn
brn-blk-brn-brn
red-red-brn-brn
brn-blk-red-gld
brn-blk-yel-gld
red-red-yel-gld
brn-gry-brn-gld
blu-gry-red-gld
blu-gry-brn-gld
yel-vio-yel-brn
red-vio-red-gld

5-band 1%

brn-blk-blk-red-brn
yel-vio-blk-brn-brn
brn-grn-blk-red-brn
yel-vio-blk-red-brn
red-red-blk-brn-brn
brn-blk-blk-red-brn
brn-blk-blk-brn-brn
red-red-blk-blk-brn
brn-blk-blk-brn-brn
brn-blk-blk-org-brn
red-red-blk-org-brn
brn-gry-blk-blk-brn
blu-gry-blk-brn-brn
blu-gry-blk-blk-brn
yel-vio-blk-org-brn
red-vio-blk-brn-brn

Capacitors

C1	100uF 16/25VW RB electrolytic
C2,4,5,13	0.1uF/100n/104 50VW disc/monolithic
C3,9	220uF 16/25VW RB electrolytic
C6	47uF 50VW bipolar RB electrolytic
C7	33nF/0.033uF/333 63/100VW
C8	22uF/16/25VW RB electrolytic
C10	0.47uF/470n/474 63/100VW MKT
C11,12	27pF 50V NPO disc ceramic

Semiconductors

D1,2,5,6	1N4148/1N914 etc signal diode
D3,4	1N4002/4 etc power diode
Q1,3,4,5	BC328 PNP transistor
Q2,6,11,12,13	BC338 NPN transistor

Q7	BC548 NPN transistor
Q8,9,10	BC558 PNP transistor
IC1	78L05 voltage regulator
IC2	Z86E0408 microcontroller (with custom firmware)
IC3	4094 CMOS shift register
DIS1,2	Seven-segment LED displays (see text)
LED1,2	3mm LEDs (see text)

Miscellaneous

XTAL1 3.58MHz crystal, HC-49/U case
 One each 16,18, 28-pin IC sockets; '216' type battery snap lead; plastic utility box, type UB3; PC board, 95 x 57mm, code ZA1245 (96ESR1); push-on momentary pushbutton switch; two x 4mm banana sockets; pre-punched silk-screened front panel; 4 x 15mm spacers; 2 x 4mm banana plugs; 2 x mini alligator clips; PCB pins; piece of foam; red perspex display filter; hookup wire; solder.

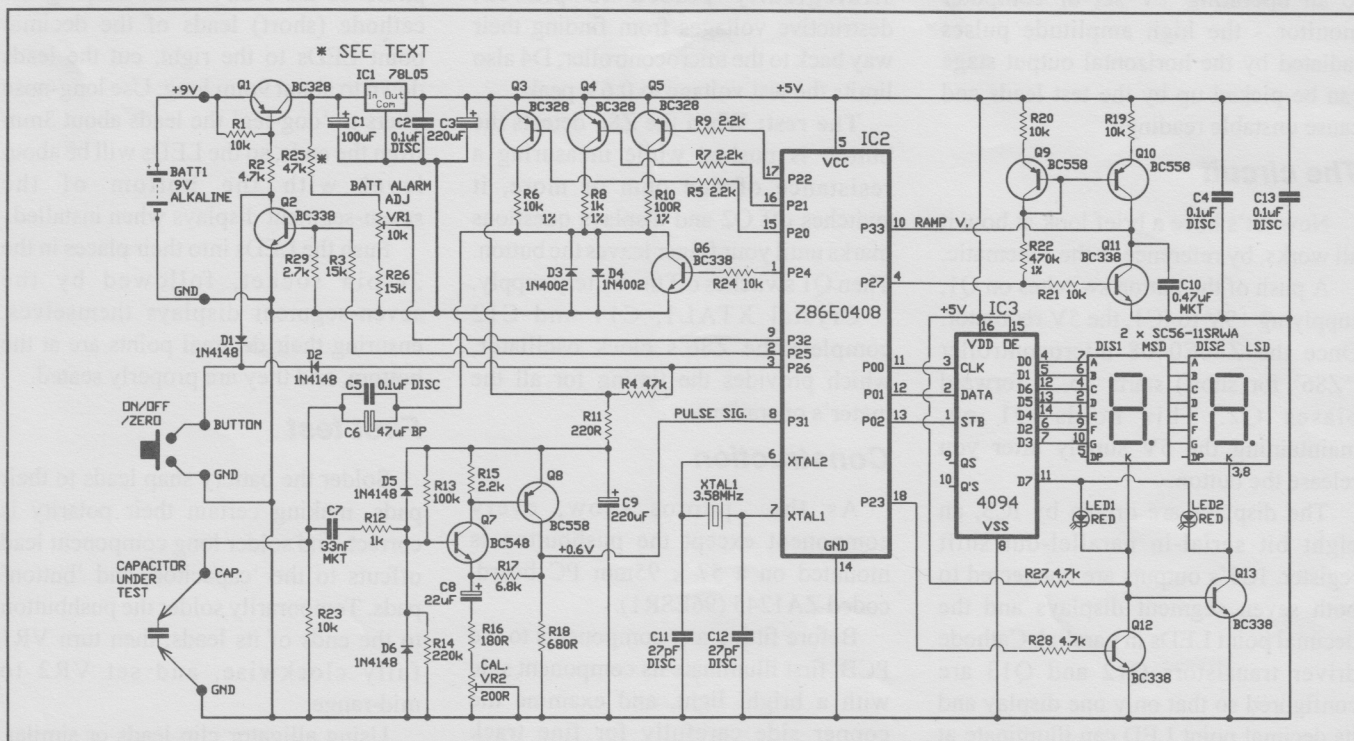

The schematic may look a little complicated, but the circuit is actually quite elegant. Everything is under the control of IC2, a low cost microcontroller. As well as auto ranging, it also compensates for test lead resistance.

Notes & Errata

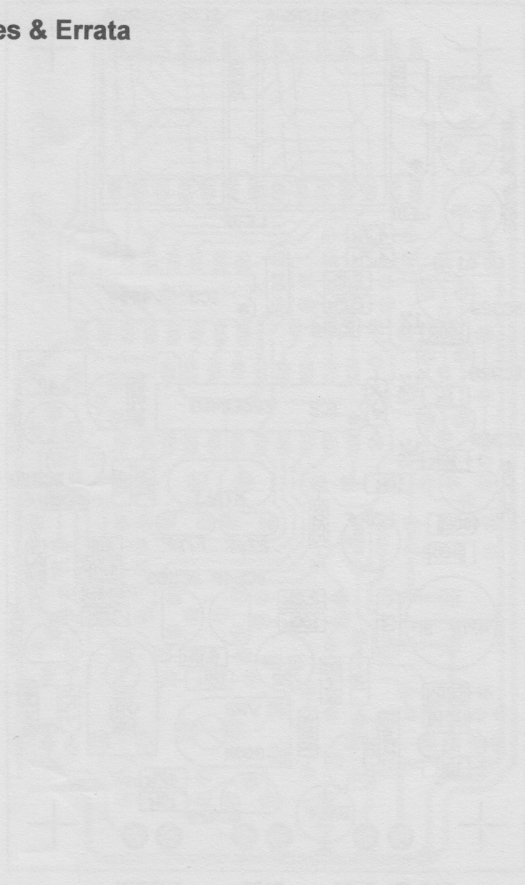

DICK SMITH
ELECTRONICS

ACN 000 445 956

CNR Lane Cove & Waterloo Roads
North Ryde NSW 2113

PH: (02) (Int 612) 937 3200 Fax: 888 3631